



RAPID OMEGA™ 100 & 200

**owner's
manual**



RAPID OMEGA 100 & 200

RAPID OMEGA 100 and 200 cameras are the latest in the world-renowned series of OMEGA professional medium-format cameras.

This manual is for RAPID OMEGA 100 and 200 models. The difference between the two models is that the Film Magazine Housing is removable on the model 200; on the 100, it is an integral part of the camera. The Roll Film Holders, Lenses, and all other components are identical between the two models, as is the operation of the camera and accessories.

They are specifically designed to give the busy professional the large-format negative quality that he needs in the profitable pursuit of his profession, plus the fast-handling ease and convenience previously offered only in an advanced 35mm camera.

We strongly urge that you read this manual thoroughly and refer to it as you acquaint yourself with your new camera. While professional experience will permit you to grasp most of its working features by examination, there are many useful and distinctive features which are not immediately apparent, and which require explanation. This manual explains them in detail.

In all circumstances, we have field-tested the camera thoroughly to determine the most convenient and efficient methods of use.

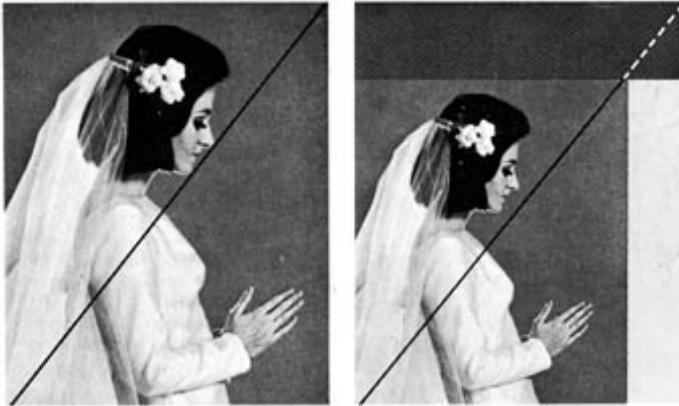

Rapid Omega 2 1/4" x 2 1/4" negative (55mmx69mm) vs. 2 1/4" x 2 1/4" negative (55mmx55mm)

Rapid Omega negative offers over 25% more actual negative area than a full 2 1/4" x 2 1/4" negative.

... and compared with the effective usable area of a 2 1/4" x 2 1/4" negative, masked for a professional vertical or horizontal format ... THE RAPID OMEGA OFFERS OVER 66% MORE TOTAL USABLE NEGATIVE AREA THAN A 2 1/4" x 2 1/4" CAMERA!

Diagonals show direct 8" x 10" proportions.

THE RAPID OMEGA NEGATIVE FORMAT – DESIGNED FOR THE PROFESSIONAL

In actual area, the Rapid Omega 2 1/4 x 2 1/4" negative format is a full 25% larger than a 2 1/4" square negative. This larger area means a smaller degree of enlargement to achieve the same print size, with consequent better rendition of detail and contrast.

But, of equal importance is the fact that the Rapid Omega format is an exact proportion of 4x5", 8x10", 11x14" and 16x20" enlargements. This means that the photographer can, if he chooses, compose his picture in the viewfinder, and print the resultant negative in all of the widely-used professional print formats, without cropping.

Rapid Omega negatives are easier to examine, easier to retouch ... and yet they are processed and developed in standard Number 120 and Number 220 tanks and reels.

3

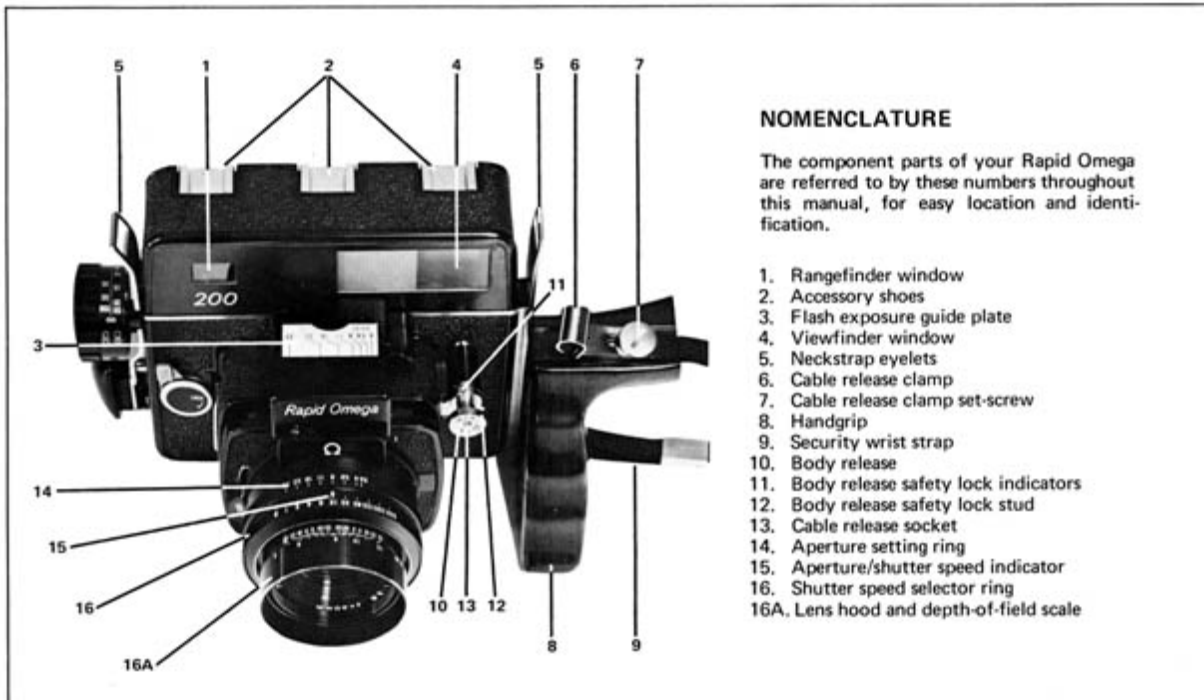

NOMENCLATURE

The component parts of your Rapid Omega are referred to by these numbers throughout this manual, for easy location and identification.

1. Rangefinder window
2. Accessory shoes
3. Flash exposure guide plate
4. Viewfinder window
5. Neckstrap eyelets
6. Cable release clamp
7. Cable release clamp set-screw
8. Handgrip
9. Security wrist strap
10. Body release
11. Body release safety lock indicators
12. Body release safety lock stud
13. Cable release socket
14. Aperture setting ring
15. Aperture/shutter speed indicator
16. Shutter speed selector ring
- 16A. Lens hood and depth-of-field scale

4

- 17. Handgrip positioning set-screw
- 18. Handgrip plate mounting screws
- 19. Flash post
- 20. Shutter cocking arm
- 21. Shutter cocking lever
- 22. Pedestal



5

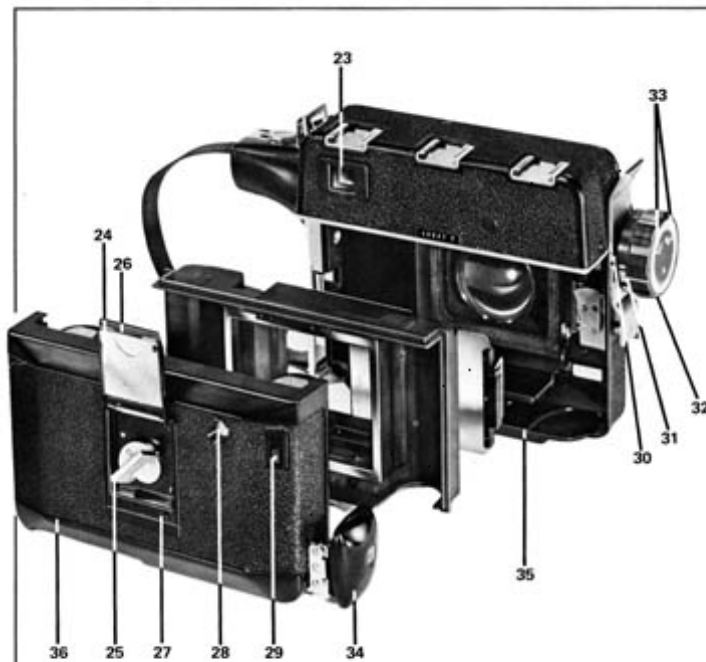

NOMENCLATURE (CONTINUED)

- 23. Viewfinder eyepiece
- 24. Film-ready indicator
- 25. Film back lock
- 26. Film-type tab holder
- 27. Film-type tab holder release button
- 28. Frame counter
- 29. Film transport release
- 30. Distance indicator arrow
- 31. Distance indicator scale for 90mm, 135mm lenses
- 32. Focusing knob
- 33. Distance scales for 58mm & 180mm lenses
- 34. Film transport knob
- 35. Tripod sockets, 1/4" and 3/8"
- 36. Dark-slide carrying slot

6

- 37. Film magazine lock (model 200 only)
- 38. Dark-slide handle
- 39. Lens interchange lock
- 40. Shutter-ready indicator
- 41. 120/220 indication
- 42. Feed-spool spindles
- 43. Take-up spool spindles
- 44. Pressure plate
- 45. Film start-mark
- 46. Magazine Housing (model 200 only)
- 47. Dark slide

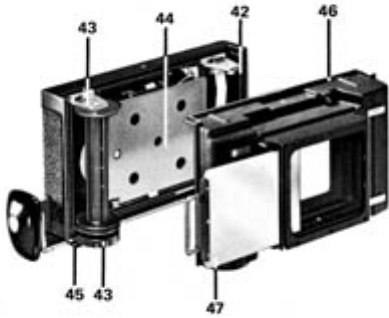

LOADING THE RAPID OMEGA 100 & 200

1. The Frame Counter (No. 28) should read LOAD. If it does not, pull the Film Transport Knob (No. 34) fully out, and return it fully until LOAD appears in the Frame Counter window. The Film Transport will lock at "10" for Number 120 Film Backs and at "20" for Number 220 Film Backs. Unlock the transport by pushing upward on the Film Transport Release (No. 29), while you continue working the Film Transport Knob until the word LOAD appears in the Frame Counter.
2. Push upward on the Film-Type Tab Holder Release Button (No. 27). The Holder will spring open. Lift the Key on the Film Back Lock (No. 25) and turn the lock until "O" (open) aligns with the white dot.
3. **DO NOT PULL ON THE KEY.** Hold the film back in your left hand and lift the Film Back off the camera body by grasping it at its sides.
4. Remove the empty spool from the Feed Spindles by pushing slightly upwards on the upper Spindle. Place the empty spool on the Take-Up Spindles pushing slightly up on the upper Spindle. Be sure that the key on the lower Take-Up Spindle engages the keyway in the film spool. Rotate the spool with your thumb until the long slot faces toward the Feed Spindles.
5. Place the fresh roll of film on the Feed Spindles with the seal unbroken, oriented so that the black inner face of the leader will face you when the film is unrolled. Break the seal and remove it from the roll.
6. Unroll sufficient paper leader so that the end may be inserted in the slot in the Take-Up spool. Rotate the Take-Up spool with your thumb to take up slack.
7. Apply light pressure with your thumb on the roll of film, and rotate the take-up spool with your other thumb. **BE SURE THE FILM IS PERFECTLY CENTERED AND TAUT.** Continue to rotate until the start-arrows printed on the backing paper of the film align with the red Film Start Mark on the Take-Up Spindle, near the Film Transport Knob on Number 120 film backs.

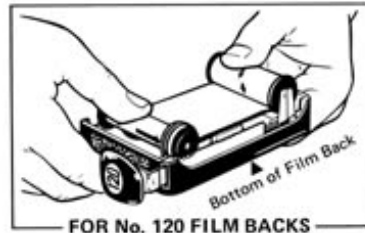

8. Be sure the Film Back Lock is in "O" position. Lower the Film Back gently into its recesses in the magazine. **DO NOT FORCE.**
9. When the Film Back is seated snugly in the magazine, turn the Film Back Lock Key to "L"; fold it down flat, and close the Film-Type Tab Holder. Grasp the Film Back at its sides and pull gently to make sure that the Back is properly locked into the magazine.
10. Draw the Film Transport Knob fully out and return it. Note that one green dot appears in the Frame Counter. Repeat this procedure. At the end of the next stroke, two green dots will appear in the Frame Counter. At the third stroke, the numeral "1" will appear in the Frame Counter of Number 120 film backs. This indicates that the first frame is in position, ready for exposure.

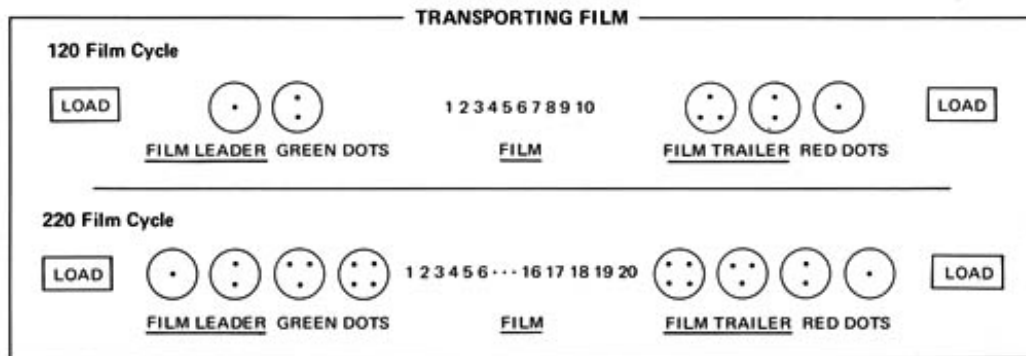

9



The procedure for loading film into Number 220 Film Backs is substantially the same, except:

- A. The Film Start Mark is located on the Feed Spindle. The Mark is an arrow pointing to a notch on the Spindle. The start arrows on the film leader must be aligned with this mark.
- B. After the word LOAD in the Frame Counter, one green dot appears when the Film Transport is actuated. This is followed by two green dots at the next stroke, then three green dots, then four green dots followed by the numeral "1" to indicate that the first unexposed frame is in position. This is necessary because of the longer film leader needed with Number 220 film, which has no paper backing.

FILM TYPE REMINDER

After the film has been loaded in the film back, tear off the small tab from the film carton containing the film-type identification. Press upward, in the direction of the arrow, on the Film-Type Tab Holder Release Button. The transparent Holder will spring open. Insert the tab from inside, so that its face will show when the Holder is closed. Swing the Holder down until it clicks shut. This informs you with what kind of film the Film Back is loaded.

After the film has been exposed and removed, remove the tab as well.

This serves as a signal that the magazine is empty. If no tab is in the holder, the Film Back Lock can be seen, indicating that the Film Back may be removed and loaded.

THE PROPER WAY TO HOLD YOUR RAPID OMEGA

Experience has proved this to be the most comfortable, convenient, and steady way to hold the Rapid Omega:

1. Slide your left hand through the Security Strap (No. 9) and grasp the Handgrip (No. 8). Your fingers should curl around the grip with the little finger below the bottom indentation, and your thumb pressing the grip from behind. In this position, your index finger will fall naturally on the Body Release (No. 10), ready to make the exposure.

NOTE: While the Security Strap is adjustable in length, it should never be tightened against the hand. Its function is to guard the camera against accidental dropping while it is being carried.

2. With the thumb and index finger of the right hand, grasp the Focusing Knob (No. 32). Permit the other fingers of your right hand to curl around the Film Transport Knob (No. 34).
3. Now, lift the camera to your eye, pressing the camera body firmly to your cheek. For more accurate results, hold your eye as close as possible to the Viewfinder Eyepiece (No. 23).

The camera is now held firmly and steadily, with an unimpeded field-of-view. You are ready to focus, expose, transport the film for the next shot, without removing the camera from your eye.



11

ADJUSTING THE HANDGRIP

The human-engineering concept embodied in your Rapid Omega attempts to allow for as wide a variance as possible in individuals.

The handgrip may be adjusted to the most comfortable angle for the size of your hand and length of your fingers by loosening the Handgrip Positioning Set-Screw (No. 17), and altering the position of the Grip. A coin does the trick nicely. Remember to re-tighten the Set-Screw once the most comfortable position has been found. Hold the camera at eye-level to make this adjustment.

THE VIEWFINDER/RANGEFINDER SYSTEM

The Rangefinder is automatically coupled to all four lenses, as they are mounted on the camera.

The Viewfinder window shows four elements of importance:

1. The outer luminous frame. This is the field of view for the "normal", 90mm lens.
2. The inner luminous frame. This is the field of view for the telephoto, 180mm lens. This frame disappears when the camera is focused for distances closer than 12 feet, reminding you that the telephoto lens cannot be used at closer distances.
3. Cameras which have the focusing knob with both the 90mm and 135mm focusing scales also show four corner dots in the finder between the outer 90mm field and the inner 180mm field. These dots delineate the corners of the field covered by the 135mm lens. These dots disappear when camera is focused closer than 7 feet, reminding you that the 135mm lens cannot be used at closer distances.
4. A bright spot in the center, in which the superimposed image of your subject will merge into one image when the camera is sharply focused.

12

TO FOCUS THE CAMERA

Rotate the Focusing Knob until the two images seen in the bright spot merge into one.

If difficulty is encountered in identifying the secondary moving image in very dim light, pass your hand or a card rapidly in front of the Rangefinder Window (No. 1), several times. The secondary image will seem to blink on and off.

NOTE: If your eye is properly positioned, directly in line with the Viewfinder, all four luminous lines will appear equally bright. If not, adjust your eye position until luminosity is uniform, to be sure that you are looking straight through the finder.

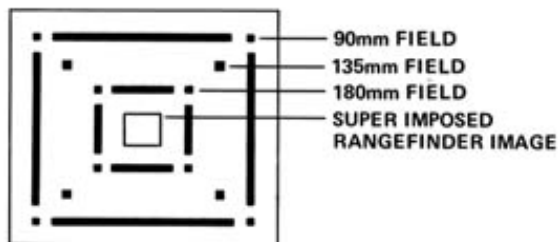

Viewfinder Window

AUTOMATIC PARALLAX AND FIELD-OF-VIEW CORRECTION

Both parallax error and alteration of the lens field-of-view are automatically compensated in the Rapid Omega. As the Focusing Knob is rotated, the luminous frame-lines will be seen to contract toward the lower right corner of the viewfinder, or to expand as the Focusing Knob is rotated to far distances. This system yields a far more accurate delineation of the field than a simple shifting frame, since it compensates simultaneously and continuously for horizontal and vertical parallax error, and for the changing of the lens-field at all distances.

13



VIEWFINDER FOR THE WIDE-ANGLE LENS

Supplied with the 58mm lens as an accessory

The 58mm wide-angle lens for the Rapid Omega has its own supplementary al bada-type optical viewfinder. It is mounted in the center Accessory Shoe (No. 2) to eliminate horizontal parallax error. It is equipped with a parallax correction mark in its upper corners to correct for vertical parallax error at distances closer than 6 feet.



SPORTSFINDER

This convenient, collapsible finder has frames for 90mm and 180mm lenses. Telephoto frame folds away when normal frame is used for viewing. Both frames and eyepiece fold flat when not in use, permitting it to be left on the camera at all times. The eyepiece features click-stop parallax compensation adjustment. The essential accessory for the action photographer.

14

LENS APERTURES AND SHUTTER SPEEDS

The Lens Aperture Setting Ring (No. 14) and the Shutter Speed Selector Ring (No. 16) are both aligned to a common Indicator (No. 15) and run in directions counter to each other. This arrangement makes it very simple to set either value by rotating the Ring to the desired click-stop position, or to change both simultaneously while retaining the same exposure value.

Once an aperture/shutter speed combination has been set, all you need do is grasp both rings simultaneously and rotate to keep the same exposure value while altering both settings. Or, of course, each Ring may be rotated individually only if a different shutter speed or lens aperture is desired.

SAFETY INTERLOCKS

1. **ON THE BODY RELEASE.** To prevent accidental exposure, especially since the Rapid Omega was designed to be carried with the index finger resting on the Body Release for quick action, the Body Release may be locked by moving the Stud (No. 12) upward until the two color indicators (No. 11) are out of line. When the Stud is moved downward and the two Indicators aligned, the Body Release is ready for firing.
2. **THE DARK SLIDE,** which prevents fogging of film when the magazine is removed or when changing lenses, engages a safety bar which locks the Body Release. The Dark Slide must be removed by pulling outward on its Handle (No. 38) before the camera can be fired. For convenience, place the Dark Slide in its Carrying Slot (No. 36) while the camera is in use, and fold the handle forward, against the base of the camera.

IF THE CAMERA
WILL NOT FIRE:

be certain that the Body Release is unlocked
be certain that the Dark Slide has been fully withdrawn
be certain that the Shutter is cocked.

15

FILM TRANSPORT

After each exposure, it is only necessary to draw the Film Transport Knob (No. 34) fully out, and push it fully back in order to transport film to the next frame. If the camera is properly held, as previously described, the bottom three fingers of the right hand accomplish this, while the thumb and forefinger return naturally to rest on the Focusing Knob. You are then ready for the next exposure.

The Film Transport returns to a slightly further-out position each time it is used. This is to assure uniform spacing between frames on the negative strip. **BUT, IT IS IMPORTANT THAT THE KNOB BE RETURNED FULLY, UNTIL IT CLICK-STOPPS IN POSITION.**

This is because, in addition to transporting film, the film transport plunger activates the exclusive Rapid Omega pressure plate system. The pressure plate retracts just before the film is moved, eliminating tension and totally avoiding all danger of scratching while film is in motion. This is exceptionally vital when using Number 220 film which has no paper backing.

At the end of each return-stroke, the plunger returns the pressure plate to its taking position, reestablishing maximum pressure on the film to keep the film absolutely flat and in the correct plane-of-focus. This interesting mechanism may be observed in action by removing the pre-load Film Back.

HOW TO OBSERVE PRESSURE PLATE ACTION

To remove the Film Back, move the Film Tab Holder Release Button (No. 27) slightly upwards, in the direction of the arrow. The Tab Holder will spring upward.

16

Raise the Key on the Film Back Lock (No. 25) and move the lock until the "O" (open) aligns with the white dot. Then, lift the Film Back gently out of the camera by grasping it at both sides. *DO NOT PULL ON THE KEY.* Return the Lock to "L" position, fold the key flat and close the Tab Holder.

Now, place the Film Back on its Back, and move the Transport Knob slightly out. Notice that the Pressure Plate drops down, but the Take-Up Reel has not yet moved. Complete the cycle by drawing the Knob fully out and returning it. Notice that, as the plunger clicks into position at the end of its travel, the Pressure Plate moves upward, into the plane-of-focus.

To replace the Film Back, re-open the Film-Type Tab Holder, lift the Film Back Lock Key and re-set the Key to "O". Replace the Film Back and lock, as described in "Loading the Film Back".

UNLOADING FILM – 120 FILM BACKS

When the Frame Counter (No. 28) reaches "10", the Film Transport locks. This is your warning that you have reached the last frame on the roll.

Release the Transport by pushing the Film Transport Release (No. 29) upward, in the direction of the arrow, and activate the Film Transport.

At the next stroke, 3 red dots will appear in the Frame Counter. On the next stroke, two red dots, then one red dot, and finally, the word LOAD.

The exposed film has been fully wound on the take-up reel. Remove the Film Back, and lift the film off the Take-Up Spindles.

17

UNLOADING FILM – 220 FILM BACKS

Substantially the same procedure is followed, except:

- A. The Film Transport will lock when the numeral "20" appears in the Frame Counter.
- B. After the last exposure has been made, the next stroke of the Film Transport will bring four red dots into the Frame Counter. At the next stroke, three red dots will appear. Then, two red dots, then, one red dot, and, finally, the word LOAD.

This is because a longer length-of trailer is needed with number 220 film, which has no paper backing.

The Film Back is now ready for its next roll of film. (See LOADING)

SHUTTER COCKING IS AUTOMATIC

When the film is transported to the next unexposed frame, the shutter is automatically cocked. Each of the four lenses designed for use with the Rapid Omega has a Shutter Cocking Lever (No. 21) which engages a Shutter Cocking Arm (No. 20) coupled to the film transport mechanism.

18

INTENTIONAL DOUBLE EXPOSURES

Normally, your Rapid Omega prevents double exposures through its automatic shutter cocking mechanism. If a double exposure is desired, the Shutter Cocking Lever (No. 21) may be moved manually to the end of its slot which cocks the shutter. This will permit re-exposure of the frame without transporting the film.

FILM-READY AND SHUTTER-READY INDICATORS

The Film-Ready Indicator (No. 24) is located on the top of the Film Back, just above the Film Type Tab Holder. When an unexposed frame of film is in position, this Indicator shows a colored dot. At the moment the frame is exposed, the dot turns black, and remains so until a fresh frame is transported into taking position.

The Shutter-Ready Indicator (No. 40) shows a colored dot when the shutter is cocked, and goes blank the instant the exposure is made.

These two indicators, in addition to avoiding missed shots, are an invaluable aid when magazines are interchanged mid-roll with the Rapid Omega 200. (See INTERCHANGING MAGAZINES)

IMPORTANT: To assure trouble-free operation of the shutters in RAPID OMEGA lenses, try to avoid leaving the shutters cocked for extremely long periods of time (several weeks or more). Should you wish to store your camera for such a period and the shutter is cocked, release it by pressing the shutter release while the lens cap is on; then, re-cock the shutter manually by moving the Shutter Cocking Lever (No. 21) when you are again ready to shoot.

19

INTERCHANGING LENSES

The four lenses designed for use with your Rapid Omega camera are partners in quality with the camera itself. They are made to critical professional standards of correction and image-formation, anti-reflection coated, and include new types of rare-earth optical glass, rendering critically high resolution.

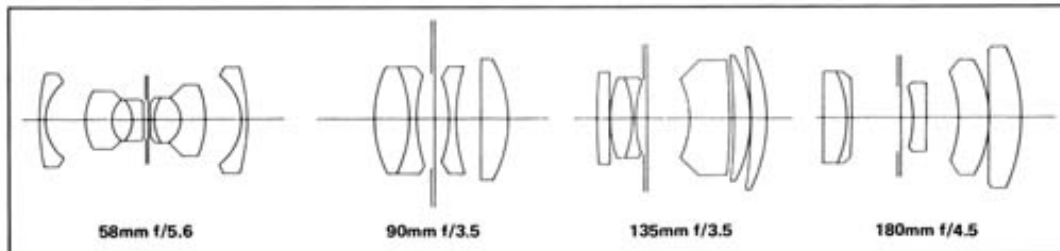

1. WIDE-ANGLE LENS: 58mm f/5.6. Minimum aperture f/32. 8 elements, 4 groups. Angle-of-view 61°. Filter series No. 7 for thread-in retaining ring.
2. STANDARD LENS: 90mm f/3.5. Minimum aperture f/32. 6 elements, 3 groups. Angle-of-view, 42° 20'. Filter series, No. 6 for thread-in retaining ring.
3. MEDIUM TELEPHOTO LENS: 135mm f/3.5. Minimum aperture, f/32. 6 elements, 5 groups. Angle-of-view, 29°. Filter series No. 8, for thread-in retaining ring.
4. TELEPHOTO LENS: 180mm f/4.5. Minimum aperture, f/32. 5 elements, 4 groups. Angle-of-view, 21° 50'. Filter series, No. 8 for thread-in retaining ring.

TO REMOVE THE LENS

1. Place the camera on its back, and rotate the Focusing Knob until the lens is fully retracted, at infinity.
2. Check to be certain that the Dark Slide is *fully* inserted in its slot behind the lens.
3. Move the Lens Interchange Lock (No. 39) upward, opposite to the direction of the arrow, and lift the lens straight up out of its mounting.

TO MOUNT THE LENS

1. Hold the lens by its barrel with the flat tab bearing the Omega symbol directly under the words Rapid Omega on the lens housing.
2. Place the lens gently into place. All pins should fit easily and snugly into their slots. **DO NOT FORCE.**
3. Move the Lens Interchange Lock fully downward, in the direction of the arrow, until it clicks into place.

SOME GENERAL INFORMATION ABOUT RAPID OMEGA LENSES

All four lenses for your Rapid Omega are equipped with built-in, retractable lens hoods, to avoid the nuisance of carrying and mounting individual hoods on each lens. To erect the lens hood, after the lens has been mounted, simply pull it out with your fingers as far as it will go.

All Rapid Omega lenses are provided with front lens caps. The telephoto and wide-angle lenses are also provided with cases. After removing a lens, it is a good idea to cap it immediately, and store it in a case until it is to be used again. No rear cap is provided with the telephoto lens because the case safeguards the rear of the lens.

NOTE: Before using your new camera for the first time, make sure that the rear lens cap for the standard (90mm) lens has been removed.

21

INTERCHANGING MAGAZINES (RAPID OMEGA 200 ONLY)

The preloaded, interchangeable magazines which are a distinctive feature of your Rapid Omega, are a boon to the busy photographer. They permit instant re-load without winding, to avoid loss of pictures. They permit interchange mid-roll of one film-type to another without the loss of a single frame.

TO REMOVE THE MAGAZINE

1. Insert the Dark Slide fully in its slot behind the lens. Easiest way to do this is to insert a lower corner first. Then, straighten the slide and push it in. Snap the Dark Slide Handle forward, toward the lens.
2. Move the Film Magazine Lock (No. 37) down, opposite to the direction of the arrow.
3. Grasp the magazine by its sides, and lift at the side with the Film Transport Knob. The magazine is retained by a spring clip at the opposite side.
4. Swing the magazine free and lift out of its spring clip. (See illustration)

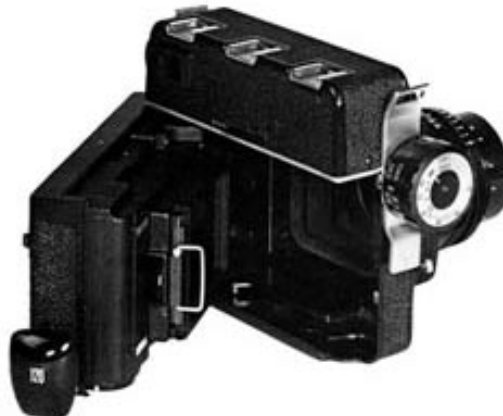

22

TO REPLACE THE MAGAZINE (RAPID OMEGA 200 ONLY)

1. Be certain that the Handle of the Dark Slide is snapped forward so that it passes easily through its opening in the body of the camera.
2. Slip the stud on the magazine under the spring clip on the left side of the body. This clip is located on the side of the magazine nearest the Handgrip. Swing the Magazine closed at the side opposite the spring clip, checking to be certain that the Handle of the Dark Slide emerges at the front of the camera.

CAUTION: DO NOT FORCE – If the Magazine will not swing fully closed, check to be certain that the Handle of the Dark Slide is pointed forward and emerges through the front of the camera.

3. Press gently on the Magazine to hold it fully closed and move the Magazine Lock up, in the direction of the arrow.

Be sure to remove the Dark Slide and place it in its carrying slot before attempting to make exposures.

AFTER INTERCHANGING MAGAZINES MID ROLL

1. Check the Film Ready Indicator (No. 24). If it shows blank, the frame of film in taking position has already been exposed. Actuate the Film Transport plunger to bring a fresh frame of film into the film plane, and to cock the shutter. If the shutter is already cocked, it will remain so while film is transported.

If the indicator shows a colored dot, the frame is ready to be exposed.

2. Check the Shutter-Ready Indicator (No. 40). If it shows a colored dot, the shutter is cocked, and ready to fire. If it shows blank, and you don't want to transport a fresh frame of film, push the Shutter Cocking Lever (No. 21) as far as will go in its slot. This will cock the shutter without transporting film.

23

FILM-LENGTH INDICATORS

Magazines for the Rapid Omega 200 and Roll Film Backs for the Rapid Omega 100 are available to accept Number 120 (ten exposure) and Number 220 (twenty exposure) film.

The length of the film which the Roll Film Back was designed is indicated by a large indicator (No. 41) on the face of the Film Transport Knob.

The Frame Counter will indicate "10" on a Number 120 Roll Film Back before locking. On a Number 220 Roll Film Back it will indicate "20."



AUTOMATIC FILM MARGIN IDENTIFICATION

This is an extraordinarily useful feature of your Rapid Omega. It permits you to identify jobs, assignments, magazines, by the number of dots that register in the margin of the film when the exposure is made. Any number of dots from one through nine may be used.

Remove the Film Back, and observe the nine small holes drilled in the aperture frame, at the lower left corner of the magazine housing. Just inside the frame is a sliding bar with two projecting tabs. Move the bar fully to the right.

The best way to set the bar is to observe the reflection of the nine holes, in the dark slide. Move the bar until the desired number of holes remain uncovered. These holes will appear as sharp little dots on the margin of the negative, on each frame exposed with that magazine.

TRIPOD SOCKETS

Your Rapid Omega has four Tripod Sockets. On the base of the camera you will find two Tripod Sockets (No. 35), one for standard 1/4" American thread, the other for standard 3/8" European thread. These are for mounting the camera in a horizontal format.

For vertical format, two additional tripod sockets are located on the other side of the camera, under the Handgrip mounting plate. To use these sockets, loosen and remove the Handgrip Plate Mounting Screws (No. 18). The screw-holes then serve as tripod sockets. A coin serves this purpose nicely.



CABLE RELEASE

The Cable Release Socket (No. 13) on the Body Release accepts standard cable release tips, but it is recommended that the special Rapid Omega cable release, available from your dealer as an accessory, be used. This release has a plunger long enough to activate the Film-Ready Indicator, as well as trip the shutter, when the plunger is pushed in fully.

In addition, this cable release may be inserted through the Cable Release Clamp (No. 6) on top of the Handgrip for those who prefer to make exposures from behind the camera, with the thumb of the left hand. The position of the Cable Release Clamp is adjustable by loosening its Set-Screw (No. 7) with a coin, and retightening at the most comfortable position.

NOTE: The Body Release Lock is not coupled to the Cable Release. Thus you must be sure the dark slide is fully withdrawn before using the cable release for releasing the shutter.

25

TIME EXPOSURES

When the Shutter Speed Selector Ring is moved to "B" the shutter will remain open as long as the Body Release is pressed.

Of course, the use of a tripod and a cable release is recommended for maximum sharpness with time exposures. For this purpose, the Rapid Omega cable release is equipped with a knurled lock-ring. When this ring is rotated, the plunger will remain locked in its fully extended position, once it has been depressed. A slight downward pressure on the ring permits the plunger to snap back.

When the lock-ring is not used, the Cable Release operates in a conventional manner.

CALCULATING DEPTH-OF-FIELD

WITH THE STANDARD LENS

A convenient Depth-of-Field Scale (No. 16A) is engraved on the Lens Hood of the 90mm lens.

After the camera has been focused, note the distance that appears on the Distance Scale (No. 31) aligned with the Distance Indicator Arrow (No. 30). Rotate the lens hood until this figure aligns with the white triangle (symbol) on the top of the lens housing. The Depth-of-Field Scale will now give you the approximate depth-of-field limits for any lens aperture.

WITH TELEPHOTO AND WIDE-ANGLE LENSES

The Distance Scales on the side of the Focusing Knob (for 58mm and 180mm lenses) tell you the focusing distance. For 135mm lens the distance scale is on the rim of the Focusing Knob next to the 90mm scale.

Rapid Omega Depth of Field Table for 58mm f/5.6 (Circle of Confusion 0.0583mm)

		Distance in Feet									
f:1	1.2'	1.5'	2'	2.5'	3'	4'	6'	10'	20'	∞	
5.6	1'02"	1'05"	1'11"	2'04"	2'10"	3'08"	5'03"	8'00"	13'01"	36'07"	
	1'03"	1'06"	2'00"	2'07"	3'02"	4'04"	6'11"	13'04"	42'10"	∞	
8	1'02"	1'05"	1'11"	2'04"	2'09"	3'06"	5'00"	7'04"	11'06"	25'09"	
	1'03"	1'06"	2'01"	2'08"	3'03"	4'06"	7'06"	15'08"	85'07"	∞	
11	1'02"	1'05"	1'10"	2'03"	2'08"	3'05"	4'08"	6'09"	9'11"	18'10"	
	1'03"	1'06"	2'01"	2'08"	3'04"	4'09"	8'04"	20'01"	∞	∞	
16	1'02"	1'05"	1'10"	2'02"	2'07"	3'02"	4'03"	5'11"	8'01"	13'01"	
	1'03"	1'06"	2'02"	2'10"	3'07"	5'04"	10'02"	38'09"	∞	∞	
22	1'02"	1'04"	1'09"	2'01"	2'05"	3'00"	3'11"	5'02"	6'08"	9'08"	
	1'03"	1'07"	2'03"	3'00"	3'11"	6'01"	14'02"	∞	∞	∞	
32	1'02"	1'04"	1'08"	2'00"	2'03"	2'09"	3'05"	4'03"	5'03"	6'09"	
	1'04"	1'08"	2'05"	3'05"	4'07"	8'04"	42'11"	∞	∞	∞	

27

Rapid Omega Depth of Field Table for 90mm f/3.5 (Circle of Confusion 0.0583mm)

		Distance in Feet											
f:1	2'	2.5'	3'	3.5'	4'	5'	6'	8'	12'	20'	50'	∞	
3.5	1'11"	2'05"	2'11"	3'05"	3'10"	4'10"	5'09"	7'07"	11'01"	17'05"	36'05"	130'09"	
	2'00"	2'06"	3'00"	3'06"	4'01"	5'01"	6'02"	8'05"	13'01"	23'04"	79'11"	∞	
4	1'11"	2'05"	2'11"	3'05"	3'10"	4'10"	5'09"	7'06"	10'11"	17'02"	35'01"	114'06"	
	2'00"	2'06"	3'00"	3'06"	4'01"	5'02"	6'03"	8'06"	13'03"	23'11"	87'05"	∞	
5.6	1'11"	2'05"	2'11"	3'04"	3'10"	4'09"	5'08"	7'04"	10'07"	16'03"	31'04"	81'11"	
	2'00"	2'06"	3'00"	3'07"	4'01"	5'02"	6'04"	8'08"	13'10"	26'00"	125'04"	∞	
8	1'11"	2'05"	2'10"	3'04"	3'09"	4'08"	5'06"	7'01"	10'01"	15'01"	27'01"	57'06"	
	2'00"	2'06"	3'01"	3'07"	4'02"	5'04"	6'06"	9'01"	14'09"	29'11"	360'07"	∞	
11	1'11"	2'05"	2'10"	3'03"	3'08"	4'06"	5'04"	6'10"	9'06"	13'10"	23'02"	42'00"	
	2'00"	2'07"	3'01"	3'08"	4'03"	5'06"	6'09"	9'07"	16'03"	36'11"	∞	∞	
16	1'11"	2'04"	2'09"	3'02"	3'07"	4'05"	5'01"	6'05"	8'09"	12'01"	18'08"	29'00"	
	2'00"	2'07"	3'02"	3'09"	4'05"	5'09"	7'02"	10'06"	19'06"	60'09"	∞	∞	
22	1'11"	2'04"	2'09"	3'01"	3'06"	4'02"	4'10"	6'00"	7'11"	10'07"	15'02"	21'03"	
	2'01"	2'08"	3'03"	3'11"	4'07"	6'02"	7'10"	12'00"	25'09"	284'10"	∞	∞	
32	1'10"	2'03"	2'07"	3'00"	3'04"	3'11"	4'06"	5'05"	6'11"	8'10"	11'08"	14'10"	
	2'01"	2'09"	3'05"	4'02"	5'00"	6'11"	9'03"	15'10"	56'06"	∞	∞	∞	

28

Rapid Omega Depth of Field Table for 135mm f/3.5 (Circle of Confusion 0.0583mm)

		Distance in Feet									
f:1		4'	5'	6'	8'	10'	15'	30'	50'	100'	∞
3.5		3'11"	4'11"	5'10"	7'09"	9'08"	14'04"	27'04"	42'11"	74'11"	293'09"
		4'00"	5'00"	6'01"	8'02"	10'03"	15'08"	33'02"	59'10"	150'08"	∞
4		3'11"	4'11"	5'10"	7'09"	9'08"	14'03"	27'00"	42'01"	72'04"	257'02"
		4'00"	5'00"	6'01"	8'02"	10'04"	15'09"	33'08"	61'07"	162'05"	∞
5.6		3'11"	4'10"	5'10"	7'08"	9'06"	13'11"	26'00"	39'07"	65'02"	183'11"
		4'00"	5'01"	6'01"	8'03"	10'05"	16'02"	35'06"	68'00"	216'11"	∞
8		3'11"	4'10"	5'09"	7'07"	9'04"	13'07"	24'07"	36'04"	56'09"	129'00"
		4'00"	5'01"	6'02"	8'04"	10'08"	16'08"	38'06"	80'06"	438'02"	∞
11		3'10"	4'09"	5'08"	7'05"	9'02"	13'01"	23'00"	33'00"	48'11"	94'01"
		4'01"	5'02"	6'03"	8'06"	10'11"	17'06"	43'02"	104'08"	∞	∞
16		3'10"	4'09"	5'07"	7'03"	8'10"	12'05"	20'10"	28'08"	39'09"	64'11"
		4'01"	5'03"	6'05"	8'10"	11'06"	18'11"	54'02"	211'01"	∞	∞
22		3'09"	4'08"	5'06"	7'00"	8'06"	11'08"	18'09"	24'09"	32'07"	47'05"
		4'02"	5'04"	6'07"	9'03"	12'02"	21'01"	78'04"	∞	∞	∞
32		3'08"	4'06"	5'03"	6'08"	7'11"	10'08"	16'01"	20'03"	25'01"	32'11"
		4'03"	5'07"	6'11"	10'00"	13'07"	26'00"	318'08"	∞	∞	∞

Rapid Omega Depth of Field Table for 180mm f/4.5 (Circle of Confusion 0.0583mm)

		Distance in Feet									
f:1		7'	8'	10'	12'	15'	20'	30'	50'	100'	∞
4.5		6'11"	7'10"	9'09"	11'08"	14'06"	19'02"	28'01"	44'09"	80'07"	406'02"
		7'00"	8'01"	10'02"	12'03"	15'05"	20'10"	32'02"	56'08"	131'10"	∞
5.6		6'10"	7'10"	9'09"	11'07"	14'05"	18'11"	27'07"	43'7"	76'11"	326'7"
		7'01"	8'01"	10'02"	12'04"	15'07"	21'01"	32'09"	58'07"	143'00"	∞
8		6'10"	7'09"	9'08"	11'06"	14'02"	18'06"	26'09"	41'04"	70'01"	229'00"
		7'01"	8'02"	10'04"	12'06"	15'10"	21'08"	34'01"	63'03"	175'07"	∞
11		6'09"	7'08"	9'06"	11'04"	13'11"	18'01"	25'08"	38'10"	63'01"	166'10"
		7'02"	8'03"	10'05"	12'08"	16'02"	22'04"	36'00"	70'04"	245'10"	∞
16		6'08"	7'07"	9'04"	11'00"	13'06"	17'04"	24'02"	35'04"	54'01"	115'01"
		7'03"	8'05"	10'08"	13'01"	16'10"	23'08"	39'08"	86'06"	745'05"	∞
22		6'07"	7'05"	9'01"	10'09"	13'00"	16'06"	22'07"	31'11"	46'03"	84'00"
		7'05"	8'07"	11'00"	13'07"	17'08"	25'05"	45'03"	119'10"	∞	∞
32		6'05"	7'03"	8'10"	10'03"	12'03"	15'04"	20'04"	27'05"	37'04"	58'02"
		7'07"	8'10"	11'07"	14'05"	19'04"	29'02"	59'04"	341'00"	∞	∞

FLASH PHOTOGRAPHY

All four lenses for your Rapid Omega have shutters which are synchronized for electronic flash or flashbulbs at all speeds.

The Rapid Omega Flash Bracket, available from your dealer as an accessory, accepts both Graflex and Honeywell battery case clips. It slips under the Focusing Knob bracket, where a retaining pin is provided, and locks by means of a large, knurled knob to the Tripod Socket on the baseplate of the camera. In this position, it provides a firm support for the flash unit, out of the way of the camera's controls, with the battery case forming an extra hand-grip.

The locking knob is threaded, and may be used as a supplementary Tripod Socket.



FLASH CABLES: While the flash post on Rapid Omega lenses accepts most PC-tip flash cables, the use of the Rapid Omega flash cable is recommended because it locks into the flash socket by means of a threaded collar, preventing accidental loosening of the flash cable. This is a coiled 3-foot cable, equipped with a two-prong polarized plug to fit all professional flash equipment.

THE M-X SELECTOR is deliberately recessed between the Lens Aperture and Shutter Speed Selector Rings on the Lens, and requires the use of a pencil point or a similar instrument to alter its position. This is to avoid accidental mis-setting. Set X for electronic flash; M for flashbulbs.

31

BUILT-IN FLASH EXPOSURE GUIDE

This useful, time-saving feature will give you correct lens aperture setting at a glance, for any focusing distance. Your RAPID OMEGA camera is supplied with a Flash Plate pre-drawn to Guide Numbers 140 and 200: This corresponds to the light output of professional electronic flash units such as the ASCORLIGHT Candid (GN 140 at half-power, 200 at full power, when used with standard ASA 100 film). For other flash units, you may obtain blank Guide Plates from your RAPID OMEGA dealer, and inscribe them as described below.

TO PREPARE BLANK FLASH EXPOSURE GUIDE PLATES

FOR NORMAL LENS:

1. Divide the guide number for the electronic flash unit or flashbulbs you are using by 4, and set the distance scale to the resulting figure for the normal lens by rotating the Focusing Knob.
Example: Guide Number is 160. Divide by 4. Set distance scale at 40.
2. With a sharp pencil, make a mark at the precise point where the moving bar on the lens housing intersects the "4" line on the Guide Plate.
3. Repeat the procedure, dividing by 32.
Example: 160 divided by 32 is 5. Set distance scale at 5.
4. Make a second pencil mark where the bar intersects the "32" line.
5. Rotate Focusing Knob until the lens is fully extended, and the Distance Scale for the standard lens, at its side, reads "3.5". Now, lift out the Flash Exposure Guide Plate by inserting a fingernail under its holder at the half-moon cut-out, and pulling upwards and backwards. This may be difficult the first time the Guide is removed, since the holder is intentionally secured into place to avoid its loss in shipment. In this case, use a knife-blade under the lip the first time. Thereafter, this will present no problems.
6. Place a ruler, or other straight edge between the two marks made at the "4" and "32". Then draw a fine pen line between the two points. Now replace the guide plate.

32

When the camera is focused on an object to be photographed with flash, the point where the bar intersects the line you've drawn is the correct lens aperture setting for the normal lens.

FOR WIDE ANGLE AND TELEPHOTO LENSES

If the same guide number is used, repeat the procedure on the same Guide Plate, using a blue pencil for telephoto and a red pencil for wide-angle. The Guide Plate will then serve for all three lenses, using the same flash guide number. Space is provided in the lower right corner of the Guide Plate for the guide number to which that Plate applies.

FOR OTHER GUIDE NUMBERS

Additional Guide Plates are available from your dealer. These may be prepared for every guide number you consistently use. The Guide Plate slips in and out of holder very easily.

The Guide Plate is made of smooth, hard plastic. Since preparing a Guide Plate takes but a moment, it is entirely feasible to wipe a Plate clean, and prepare a new chart for use with any guide number, on the spur of the moment.



33

NECK STRAP (OPTIONAL ACCESSORY)

The Rapid Omega Neck Strap will safeguard your camera against accidental dropping. It is made of durable nylon, and is fully adjustable to any comfortable length. It attaches to the Neckstrap Eyelets (No. 5) on either side of the camera body.

TO ATTACH THE NECK STRAP

Push the loop at the end of the Neck Strap through the Eyelet before pushing the clip through. Then, push the clip through the eyelet. To detach the Neck Strap, push the clip through the eyelet first, and then the loop.



34

TAKE CARE OF YOUR CAMERA

Keep lenses capped when not in use. Store accessory lenses safely in their cases. Clean dust and dirt from lens surfaces, range-finder and viewfinder windows with a piece of lintless cleaning paper, rolled into a wad or brush, and slightly moistened with a good lens cleaning fluid.

REMOVE FINGERMARKS FROM LENS SURFACES IMMEDIATELY

Body acids can etch fingerprints into the fine coatings. If the camera has been used in very dusty places, clean the interior and exterior with a soft, well-laundered and lint-free cloth. Use a camel's hair brush to clean out large dirt particles.

NEVER USE ANYTHING METALLIC TO CLEAN ANY PART OF THE CAMERA.

ACCESSORIES

Many of the accessories available for the Rapid Omega also fit the preceding Koni-Omega "M" and Koni-Omega Rapid. These include all four lenses, the Optical Viewfinder for the Wide Angle Lens, the Sportsfinder, the Eyecup, the Flash Bracket and Cables.

The Auto-Up Close-Up attachment which permits rangefinder focusing to 22-3/4", may be used with both models.

Roll Film Backs are interchangeable between both Rapid Omega Cameras and Koni-Omega "M" models. However, these Roll Film Backs do not fit the original (Non-M) Koni-Omega Rapid Cameras.

35

PROPERTY OF _____
SERIAL NO. OF CAMERA _____ LENS _____



**BIG NEGATIVE QUALITY, WITH THE FEATURES
AND OPERATING SPEED OF AN ADVANCED '35'**

Specifications subject to change without notice.

Berkey Marketing Companies, Inc. 25-20 Brooklyn-Queens Expressway West, Woodside, N. Y. 11377 1011 Chestnut Street, Burbank, California 91502	<small>A DIVISION OF</small> Berkey Photo Inc. 
--	---

301BMC273

Printed in U. S. A.

